



Sentinel Door Curtain



1000mm, 1500mm & 2000mm wide doorways.
1800 to 2700mm mounting height.
Soffit drop rod or wall bracket mounted.
Ambient air, 3 phase electric or LPHW heating.

IDENTIFICATION

Introduction

The Dunham-Bush Sentinel door curtain is an ideal solution to the ingress of cold air due to “open doorway trading” in retail premises, or busy pedestrian traffic in commercial and public buildings.

The technology of door curtains is well proven. The vertical air stream above an open doorway provides a virtual barrier, which separates indoor and outdoor environments. This air barrier prevents “inversion” due to different air temperatures; thus reducing energy consumption, increasing internal comfort and usable floor area and will have no effect on pedestrian traffic flow.

Sentinel door curtains are designed and manufactured to the high quality synonymous with Dunham-Bush products, complemented by a wide range of options to suit most applications.

DESCRIPTION

Range

Sentinel door curtains are available in a range of models, for ambient, LPHW and electric heating. Each model is available in three sizes; Figures 10, 15 & 20

Model	Overall Length (mm)	Heating option	Nominal Duty (kW)
270-A-10	1113	Ambient	N/A
270-A-15	1621	Ambient	N/A
270-A-20	2121	Ambient	N/A
270-E-10	1113	Electric	9.0
270-E-15	1621	Electric	13.5
270-E-20	2121	Electric	18.0
270-W-10	1113	LPHW	9.5
270-W-15	1621	LPHW	14.1
270-W-20	2121	LPHW	22.6

Note: All model 270 door curtains are suitable for doorway heights between 1800mm to 2700mm.

Sentinel door curtains comprise motor, tangential fan(s), optional LPHW coil or black bar electric heating elements and electrical connection box.

All models are coated in durable polyester powder, colour white (RAL9010 30% gloss) with a satin finish.

ACCESSORIES

Sentinel door curtains are supplied with a wall mounting bracket and the remote switching control box. Control options offered as standard are:-

Switches

- On/off switch, and high/low fan speed adjustment switch.
- On 3 phase electric heating models the high/low switch automatically selects the full and 1/2 power heating settings.

Electric Heating Element

On electric heating element units, there are high temperature cutouts with both automatic and manual reset, located on the top of the casing.

Wall Hanging Bracket

All models come complete with a hanging plate for fixing to a vertical wall surface.

Special controls

Control options can be offered for remote installation to Sentinel door curtains, such as remote switches, relays, door interlocks and group control to suit particular applications. For further details contact your Dunham-Bush representative.



Simple user controls



Wall hanging bracket

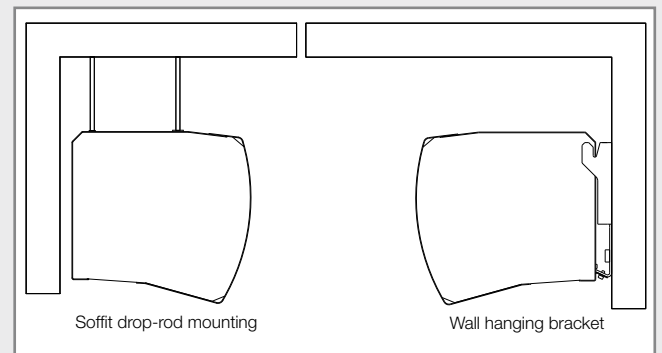

Easy and quick installation with the wall hanging bracket or drop rods

FEATURES

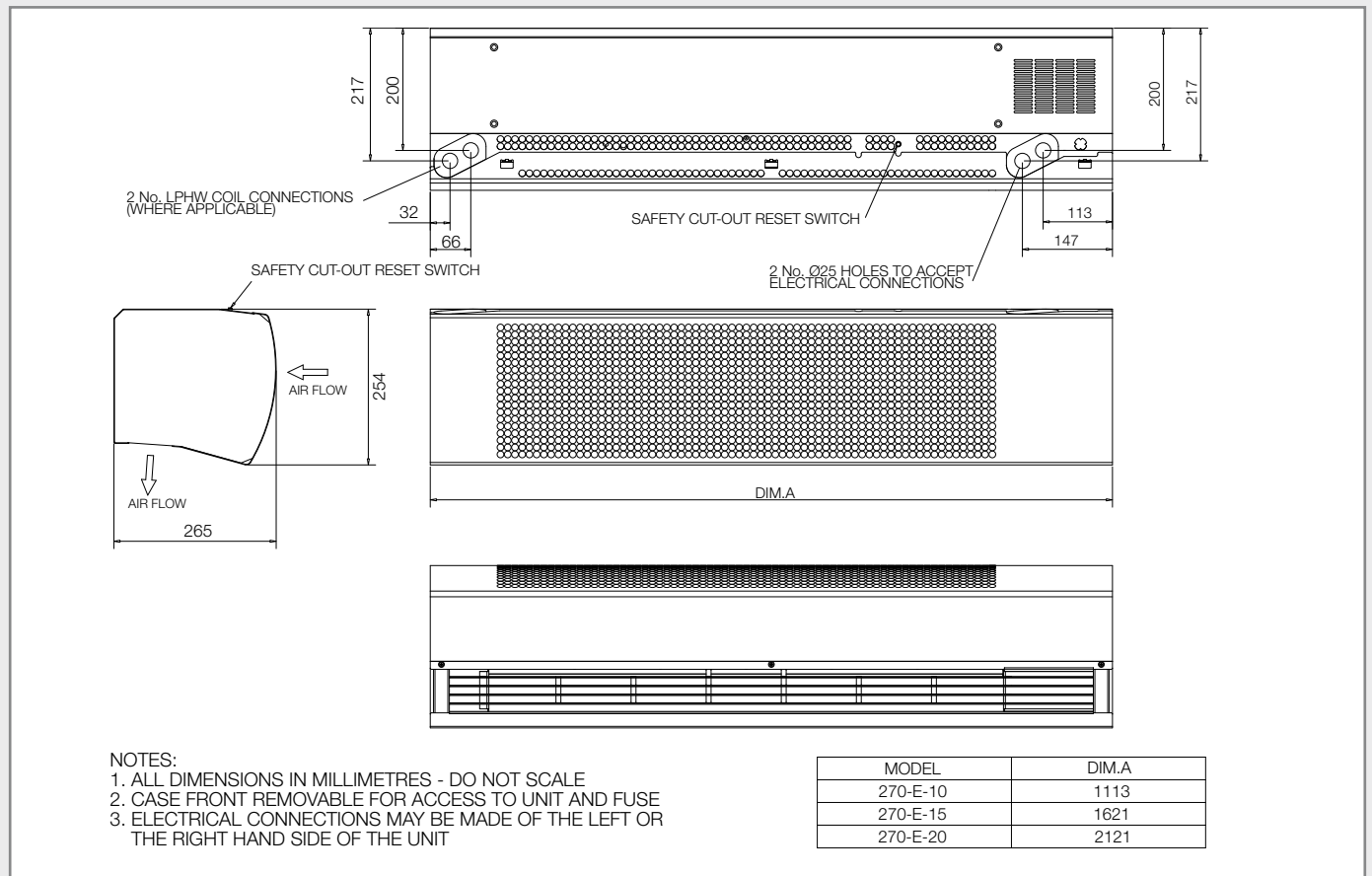

Door curtain dimensions

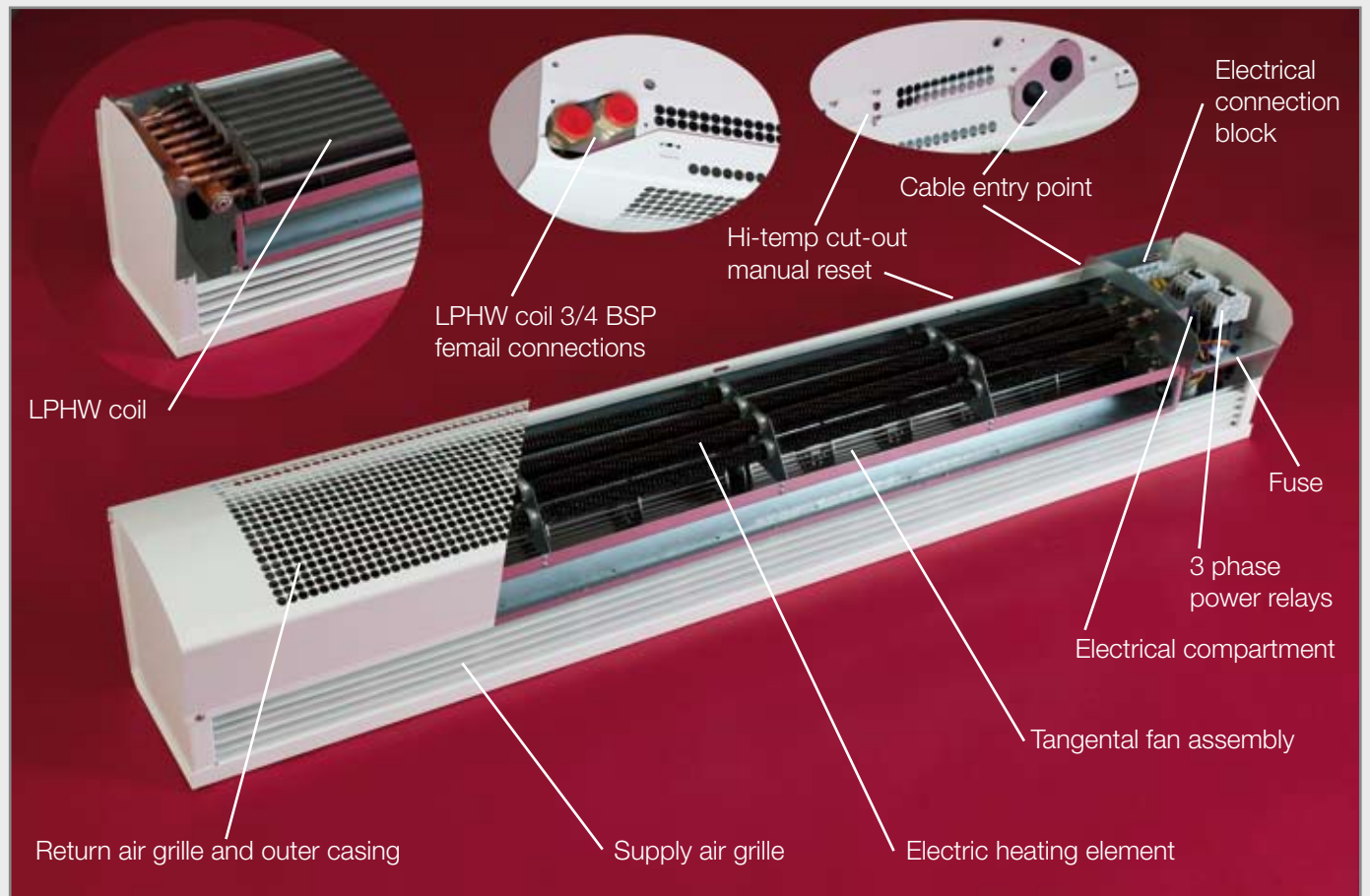

Door curtain features

PERFORMANCE

Model	270									
	A-10	A-15	A-20	E-10	E-15	E-20	W-10	W-15	W-20	
Width (mm)	1113	1621	2121	1113	1621	2121	1113	1621	2121	
Height (mm)	254	254	254	254	254	254	254	254	254	
Depth (mm)	265	265	265	265	265	265	265	265	265	
Dry mass (kg)	16.4	19.8	24.6	19.6	25.4	31.9	19.9	24.4	30.4	
Maximum discharge height (m)	2.7	2.7	2.7	2.7	2.7	2.7	2.7	2.7	2.7	
Maximum door width (m)	1.0	1.5	2.0	1.0	1.5	2.0	1.0	1.5	2.0	
Maximum air velocity (m/s)	9	9	9	9	9	9	8	8	8	
Rated current (A)	0.8	1.1	1.1	40.0	60.0	79.0	0.8	1.1	1.1	
Supply (v)	230V/1ph/50Hz			400V/3ph/50Hz			230V/1ph/50Hz			
Air volume flow rate (m ³ /h)	Low	1242	2592	3708	1444	2441	3834	1346	1901	3463
	High	1818	2736	4158	1879	2617	4100	1678	2218	3737
Air volume flow rate (l/s)	Low	345	720	1030	401	678	1065	374	528	962
	High	505	760	1155	522	727	1139	466	616	1038
Heat output (kW)	Low	-	-	-	4.50	6.75	6.00	8.20	12.70	21.60
	High	-	-	-	9.00	13.50	18.00	9.50	14.10	22.63
Air off temperature (°C) (with air on temperature 18°C)	Low	-	-	-	27.4	26.3	22.7	36.2	37.9	36.6
	High	-	-	-	32.4	33.5	31.2	34.9	37.0	36.1
LTHW mass flow rate (kg/s) (80-70°C F&R, 18°C Amb)	Low	-	-	-	-	-	-	0.196	0.303	0.516
	High	-	-	-	-	-	-	0.227	0.337	0.540
LTHW coil pressure drop (kPa)	Low	-	-	-	-	-	-	1.1	3.1	7.8
	High	-	-	-	-	-	-	1.5	3.7	8.5
SWL dBA re 1pW	Low	43	51	52	47	55	56	45	53	53
	High	56	60	59	55	59	57	54	58	56
SPL* dB re 2 × 10 ⁻⁵ Pa	Low	38	46	47	42	50	51	40	48	48
	High	51	55	54	50	54	52	49	53	51

Table 1: Selection and Performance Data

* Sound pressure level measured in a hemispherical free field at a distance of 3m from the door curtain.

Notes

- 1) Air volume flow rates estimated for figures 15 and 20 of all variants at both speeds.
- 2) SWL and SPL for figures 15 and 20 of ambient (-A) and LTHW coil (-W) variants at both speeds.

WIRING DIAGRAMS

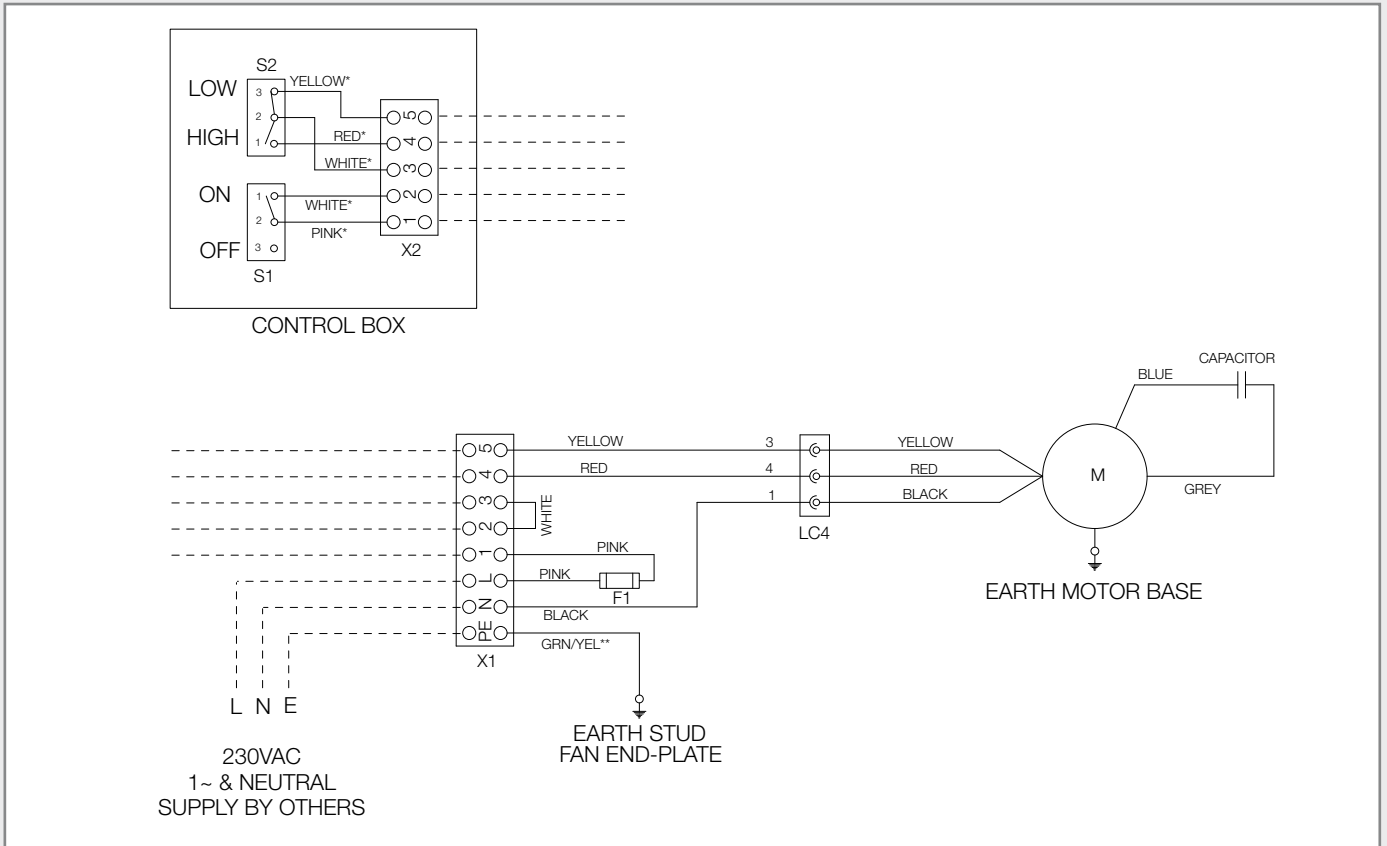

Wiring diagram - ambient air & LPHW heating

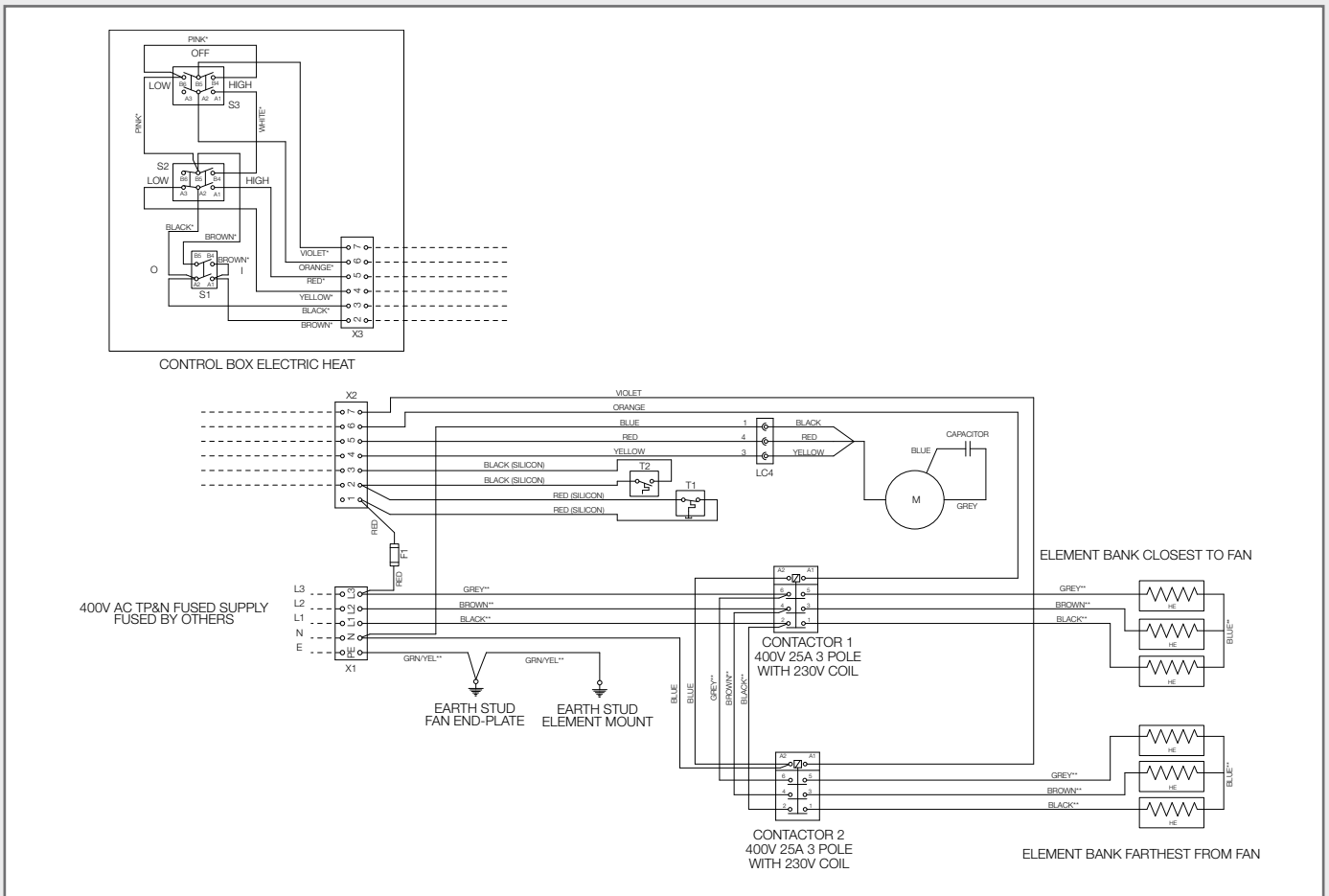

Wiring diagram - electric heating

ENGINEERING SPECIFICATION

General

The Sentinel door curtain shall be manufactured by Dunham-Bush Ltd, Downley Road, Havant, Hampshire, PO9 2JD. The models, figure numbers and quantities shall be as indicated in the schedule and /or on the drawings. The construction of all door curtains shall comply with the following specification.

Basic unit

Each Sentinel door curtain shall comprise of a sheet metal casing with access panel, heating coil/electric element, motor/fan assembly.

Hot water coil (optional)

When specified, hot water heating coils shall be provided. Coils shall be constructed from 9.35mm O.D. drawn copper tubes, expanded into single plate corrugated aluminium fins and brazed to copper headers. Flow and return connections shall be Rp3/4 to BS EN 10226 (3/4" BSP parallel female). Coils shall have a minimum cold test pressure of 16bar gauge.

Coils shall have a maximum working pressure of 12bar gauge and a maximum flow temperature of 110°C.

Electric heating elements (optional)

When specified, electric heating elements shall be rated at 400V/3ph/50Hz, supplied from a TP&N fused electrical supply and shall be configured to give the design output specified.

A self-resetting high limit thermostat set to operate at 50°C shall protect each element circuit and a manual reset thermostat set to operate at 60°C shall also protect each element circuit. The manual reset is located on top of the casing.

Fan assemblies

Fans shall be cross flow tangential type with low noise, forward curved, multi-blade aluminum impellers housed in aluminum scrolls. Fans shall be statically and dynamically balanced.

Motors

Motors shall be high efficiency, with permanent split capacitor starting and run. Each motor shall have overload protection by way of auto re-setting thermal contactors integrated into the motor windings. Motors shall have a nominal rating of 80, 100 & 120W and suitable for a 50 Hz single-phase electrical supply.

Electrical connections box

Each unit shall be provided with an electrical box. The box shall contain a terminal block for connection to the external supply and remote switches.

Fan motor speed control

Speed control shall be affected by means of a switch providing two main speeds to suit the unit duty requirements.

Packaging

Each Sentinel door curtain shall be individually packed in cartons and shall be marked with the model, figure number and serial number.

Accessories

If specified, accessories listed in the manufacturer's Product Catalogue shall be provided.



Electrical connections box



LPHW coil connections

CONSTRUCTION

Handling

The purchaser is responsible for off-loading. Two people can usually lift individual door curtains. When a significant quantity is delivered, they may be palletised, so a forklift truck, or similar form of lifting equipment, is recommended. Care should be taken to ensure the units are not dropped or suffer impact in any circumstances.

Storage

Sentinel door curtains should be stored under clean, dry indoor conditions, and any packaging should not be removed until they are ready for installation, unless damage in transit is suspected. Note - the purchaser must examine the door curtains promptly upon receipt, and any claims for damage will only be accepted, if at the time of delivery the delivery note is endorsed with a note detailing the damage and countersigned by the transport company. Each door curtain may be marked with a stencil reference if specified on the order.

Preparation

Extensive modification to the building fabric should not normally be necessary. The structure, to which the unit is to be fixed, and fixings must be capable of accepting the loads imposed by the unit and the fixings selected must be suitable for the building fabric.

Installation

Sentinel door curtains are supplied with a copy of the Installation, Operation & Maintenance Instructions, which provide full details for installing, connecting and commissioning the unit. Additional copies are available upon request, or can be downloaded from www.dunham-bush.co.uk.

Pipework Connections (LPHW)

Connections to the mains shall be Rp3/4 to BS EN 10226 (3/4" BSP parallel female) and shall be left handed (when facing the door curtain air inlet).

Electrical Connections (Ambient Air and LPHW)

Sentinel door curtain requires a 230V/1Ø/50Hz electrical supply. The electrical supply is connected to the door curtain via the terminal block.

Electrical Connections (Electric heating)

Sentinel door curtain with electric heating element requires a 400V/3Ø/50Hz TP&N electrical supply. The electrical supply shall be wired by others via Ø25mm holes in the casing to the terminal block. Cable strain relief is recommended e.g. with proprietary cable glands.

Colour

All models are finished in polyester powder, RAL9010 white, 30% gloss level.

Special colours and finishes are available, details can be provided on request.

PRICES & CONDITIONS OF SALE

Prices

Dunham-Bush do not issue price lists, but will be pleased to provide a written quotation upon request. All quotations are normally prepared through our Applications Department. For further details, please contact Dunham-Bush Ltd Head Office in Havant, Hampshire.

Conditions of Sale

Standard conditions of sale are included on the reverse of all Order Acknowledgements. Further copies are available upon request.

SUPPLY

Availability

Sentinel door curtains are supplied direct from the Dunham-Bush factory in Havant. Availability can vary with demand and should therefore be checked at the time of ordering. Contact a Dunham-Bush Representative for typical lead times.

Packaging

Sentinel door curtains are packed for storage in dry, indoor conditions. If specified, each unit will be marked with its own unique stencil reference for onsite identification.

Delivery

Sentinel door Curtains are delivered to site in accordance with our Conditions of Sale. The buyer is responsible for off-loading and storage.

TECHNICAL SUPPORT SERVICES

Product Support

In the United Kingdom and Ireland, Dunham-Bush has a network of Representatives situated at strategic locations, to provide local support on pricing and selection. Further technical support is available at the Dunham-Bush Head Office.

Tel. 023 9247 7700
Fax. 023 9245 3601
email heating@dunham-bush.com



Dunham-Bush Ltd

Downley Road
Havant
Hampshire
PO9 2JD

Tel. 023 9247 7700

Fax. 023 9245 3601

Email: heating@dunham-bush.com

www.dunham-bush.co.uk



BS EN ISO 9001: 2008

Manufacturer reserves the right to
change any product specification
without notice

PDS-1000-H-0267-01

Sept 2011